

READY

THE INNOVATOR OF OUR INDUSTRY[®]

SinterLube[®] Alloy Bushings

The Innovative Upgrade to Graphite Plug Bushings



A Complete Line for Dies and Molds

U.S. and International Patents Pending

SinterLube® - The No Maintenance, Self-Lubricating Bushing

After years of research and manufacturing process development, READY Technology proudly announces its latest and most dramatic contribution to our industry – the SinterLube® Alloy Bushing. This revolutionary product requires no lubrication during production, yet it maintains its initial geometry and undergoes negligible wear, even after millions of press cycles.

SinterLube® delivers what no other bushing can:

1. SinterLube® doesn't merely claim to be self-lubricating, it truly is self-lubricating, and it doesn't abrade or close in on the guide pin like ordinary graphite plug bushings.
2. SinterLube® has a tolerance comparable to precision guiding as opposed to the liberal tolerance of ordinary graphite plug bushings.
3. Unlike the competition, with SinterLube®, there's virtually no wear, even in the toughest applications.

Simply put, SinterLube® outperforms the competition. Try SinterLube® for yourself and discover why this revolutionary bushing should become the standard for your tooling.

The Secret of SinterLube®

Our key breakthrough in developing the product was the discovery of an alloy material having good sliding lubricity and hardness, which we then added to the bronze powder of our sintered bushings. Properly combined, the dispersed particles of the alloy remain disconnected to the bronze micro structure when sintered, providing lubricity and hardness without harming the mechanical properties of the bronze. This results in a wear resistant micro structure which outperformed every competitor's bushing we tested.

The graph (left) compares the performance of a commercially available bronze bushing with graphite plugs to our SinterLube® Bushing. We life tested both bushings at the same time; they were mounted in a split punch holder and forced apart by a gas spring so that the lateral force on each bushing was identical. We gave the SinterLube® Bushing a single application of lubricant at the start of the test and no lubricant thereafter.

Once the press had cycled over 1.2 million strokes we stopped the test and examined the bushing. Many of the graphite plugs of the competitor's bushing had extruded, and the inside diameter had grown by .053". The guide pillar literally rattled in the bushing hole. The inside diameter of the SinterLube® Bushing was smooth and had grown only .001". As you can see from the graph, the SinterLube® Bushing ran about 100°F cooler than the graphite plug bushing throughout the test, showing better lubricity.

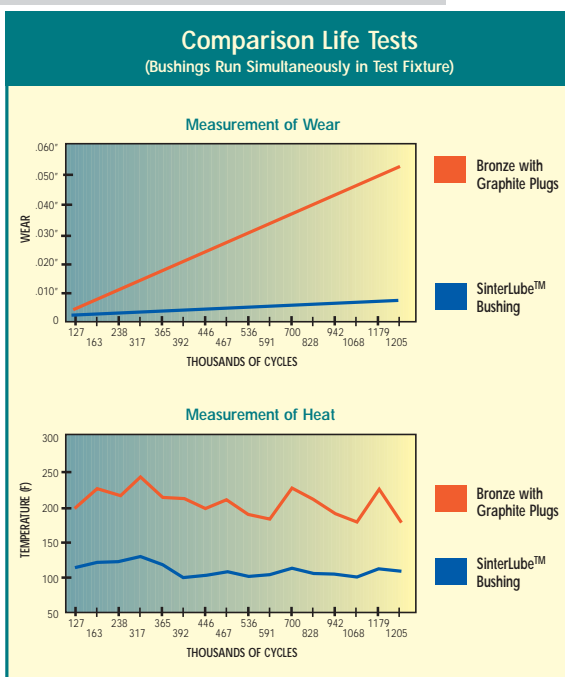

SinterLube® Bushings wear less and run cooler than ordinary graphite plug bushings.

But There's More:

Features

In addition to its attractive silver exterior and polished bronze interior, the SinterLube® Alloy Bushing has the following distinguishing characteristics:

- There is no lubrication hole or oil groove, reflecting the fact that SinterLube Bushings are designed to operate with only a single initial application of lubricant.
- The steel substrate is unhardened. Wear resistant alloy materials are contained in the bronze mixture; in effect the wear hardness is embedded in the bronze.
- A color code identifies the size of the inside diameter. By matching this color with the appropriately color coded pin, a close, standard, or loose running fit can be selected.
- The bronze layer is 11-12 times thicker than that of a plated bronze bushing, so there is no risk of wearing through to the steel substrate. Even under the most severe wear conditions the SinterLube® Alloy Bushing maintains its lubricated bearing surface.

Benefits - 10 Reasons to Switch to SinterLube®

Here are a few of the advantages of SinterLube® Alloy Bushings, which our testing has so far uncovered:

1. Graphite plug bushings operate at higher temperatures so they require larger running clearances. The minimum running clearance needed for a SinterLube® Bushing is two to three times smaller, so close tolerance stamping work can now be performed with lubrication free bushings.
2. SinterLube® Bushings resist wear, so guiding accuracy is maintained throughout the production run.
3. Standard SinterLube® Bushing clearances make die set disassembly and reassembly much easier than with loose fitting graphite plug bushings, which allow the punch holder to cock and jam.
4. An initial application is all that's required to operate SinterLube® Bushings successfully, but if additional lubrication is applied during the production run, no harm is done. By contrast, lubrication of a graphite plug bushing results in a sticky mess, making it hard to disengage the bushing from the guide pin.
5. Due to the rapid wear rate of graphite plug bushings many stampers replace the bushings at each die regrind. This is a needless expense which SinterLube® bushings eliminate.
6. We have not yet discovered the maximum speed at which SinterLube® Bushings can run, but press speeds of 800 strokes per minute at 1" stroke are well within its performance range. Many high speed tools requiring ball bearing guiding can now be fitted with SinterLube® Bushings and benefit from the greater rigidity as well as the lower cost of solid guiding.
7. According to our tests, bronze plated bushings operate well so long as they are lubricated every shift. SinterLube® Bushings do not require that nagging maintenance chore. Regular lubrication no longer needs to be policed on your stamping line.
8. At high operating temperatures graphite plugs become dislodged as the bonding glue melts. SinterLube® Bushings do not contain any glue and are entirely suitable for hot stamping or high temperature mold applications.
9. SinterLube® Alloy Bushings require less machining to produce, so they cost less than graphite plug bushings.
10. SinterLube® Alloy Bushings are interchangeable with our sintered bronze bushings, so you can easily test our assertions for yourself and install a set of SinterLube® Bushings during your tool's next scheduled maintenance.

COMPONENTS FOR DIES AND MOLDS

Guide Pins - INCH DANLY Standard	4
Bushings - INCH DANLY Standard	5
Guide Pins - METRIC DANLY Standard	6
Bushings - METRIC DANLY Standard	7
Guide Pins NAAMS Standard	8
Bushings NAAMS Standard	9
Guide Pins DIN Standard 9833	10
Bushings DIN Standard 9834	11
Guide Pins AFNOR Standard	12
Bushings AFNOR Standard	13
Guide Pins for Molds - INCH	14
Bushings for Molds - INCH.....	15
Guide Pins for Molds - METRIC.....	16
Bushings for Molds - METRIC	17
A Closer Look	18
Other Products	19

Precision Pin Selection Guide (-825)

Nominal Pin Diameter O	Length L	Catalog Number	Nominal Pin Diameter O	Length L	Catalog Number
1"	3 1/4	5-0813-825	1 3/4"	5	5-1420-825
	3 3/4	5-0815-825		5 3/4	5-1423-825
	4 1/4	5-0817-825		6 1/2	5-1426-825
	4 1/2	5-0818-825		7	5-1428-825
	4 3/4	5-0819-825		7 1/2	5-1430-825
	5	5-0820-825		8	5-1432-825
	5 1/4	5-0821-825		8 1/2	5-1434-825
	5 1/2	5-0822-825		9	5-1436-825
	5 3/4	5-0823-825		9 1/2	5-1438-825
	6	5-0824-825		10	5-1440-825
	6 1/2	5-0826-825		10 1/2	5-1442-825
	7	5-0828-825		11	5-1444-825
	7 1/2	5-0830-825		11 1/2	5-1446-825
	8	5-0832-825		12	5-1448-825
8 1/2	5-0834-825	12 1/2	5-1450-825		
9	5-0836-825	13	5-1452-825		
1 1/4"	4 1/4	5-1017-825	2"	14	5-1456-825
	4 3/4	5-1019-825		15	5-1460-825
	5 1/4	5-1021-825		17	5-1468-825
	5 1/2	5-1022-825		5 3/4	5-1623-825
	5 3/4	5-1023-825		6 1/2	5-1626-825
	6	5-1024-825		7 1/4	5-1629-825
	6 1/2	5-1026-825		7 1/2	5-1630-825
	7	5-1028-825		7 3/4	5-1631-825
	7 1/2	5-1030-825		8	5-1632-825
	8	5-1032-825		8 1/2	5-1634-825
	8 1/2	5-1034-825		9	5-1636-825
	9	5-1036-825		9 1/2	5-1638-825
	10	5-1040-825		10	5-1640-825
	11	5-1044-825		10 1/2	5-1642-825
12	5-1048-825	11	5-1644-825		
1 1/2"	4 1/4	5-1217-825	2 1/2"	11 1/2	5-1646-825
	5	5-1220-825		12	5-1648-825
	5 3/4	5-1223-825		12 1/2	5-1650-825
	6	5-1224-825		13	5-1652-825
	6 1/2	5-1226-825		14	5-1656-825
	7	5-1228-825		15	5-1660-825
	7 1/2	5-1230-825		16	5-1664-825
	8	5-1232-825		17	5-1668-825
	8 1/2	5-1234-825		18	5-1672-825
	9	5-1236-825		8	5-2032-825
	9 1/2	5-1238-825		8 3/4	5-2035-825
	10	5-1240-825		9 1/2	5-2038-825
	10 1/2	5-1242-825		10	5-2040-825
	11	5-1244-825		11	5-2044-825
11 1/2	5-1246-825	12	5-2048-825		
12	5-1248-825	13	5-2052-825		
12 1/2	5-1250-825	14	5-2056-825		
13	5-1252-825	17	5-2068-825		
14	5-1256-825	18	5-2072-825		
1 3/4"			3"	20	5-2080-825
				8	5-2432-825
				9	5-2436-825
				10	5-2440-825
				11	5-2444-825
				12	5-2448-825
				13	5-2452-825
				14	5-2456-825
				17	5-2468-825
				20	5-2480-825

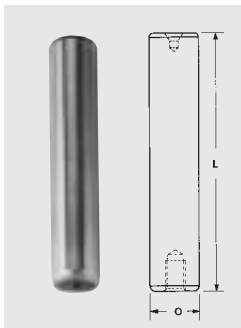

Demountable Pin Selection Guide (-835)

Nominal Pin Diameter O	Flange B	Length E	Length F	Catalog Number	Nominal Pin Diameter O	Flange B	Length E	Length F	Catalog Number
1"	1.31	7/8"	4	5-0816-835	2"	2.50	1 15/16"	5	5-1620-835
			4 1/2	5-0818-835				5 1/2	5-1622-835
			5	5-0820-835				6	5-1624-835
			5 1/2	5-0822-835				6 1/2	5-1626-835
			6	5-0824-835				7	5-1628-835
			6 1/2	5-0826-835				7 1/2	5-1630-835
			7	5-0828-835				8	5-1632-835
			7 1/2	5-0830-835				8 1/2	5-1634-835
			8	5-0832-835				9	5-1636-835
			8 1/2	5-0834-835				9 1/2	5-1638-835
			9	5-0836-835				10	5-1640-835
			9 1/2	5-0838-835				11	5-1644-835
10	5-0840-835	12	5-1648-835						
1 1/4"	1.56	1 3/16"	4	5-1016-835	2 1/2"	3.00	1 15/16"	5	5-2020-835
			4 1/2	5-1018-835				5 1/2	5-2022-835
			5	5-1020-835				6	5-2024-835
			5 1/2	5-1022-835				6 1/2	5-2026-835
			6	5-1024-835				7	5-2028-835
			6 1/2	5-1026-835				7 1/2	5-2030-835
			7	5-1028-835				8	5-2032-835
			7 1/2	5-1030-835				8 1/2	5-2034-835
			8	5-1032-835				9	5-2036-835
			8 1/2	5-1034-835				9 1/2	5-2038-835
			9	5-1036-835				10	5-2040-835
			9 1/2	5-1038-835				11	5-2044-835
10	5-1040-835	12	5-2048-835						
1 1/2"	1.87	1 7/16"	5 1/2	5-1222-835	3"	3.50	2 3/16"	6	5-2424-835
			6	5-1224-835				7	5-2428-835
			6 1/2	5-1226-835				8	5-2432-835
			7	5-1228-835				9	5-2436-835
			7 1/2	5-1230-835				10	5-2440-835
			8	5-1232-835				11	5-2444-835
			8 1/2	5-1234-835				12	5-2448-835
			9	5-1236-835				14	5-2456-835
			9 1/2	5-1238-835				16	5-2464-835
			10	5-1240-835				5	5-1420-835
			10 1/2	5-1242-835				5 1/2	5-1422-835
			11	5-1244-835				6	5-1424-835
11 1/2	5-1246-835	6 1/2	5-1426-835						
12	5-1248-835	7	5-1428-835						
12 1/2	5-1250-835	7 1/2	5-1430-835						
13	5-1252-835	8	5-1432-835						
14	5-1256-835	8 1/2	5-1434-835						
		9	5-1436-835						
		9 1/2	5-1438-835						
		10	5-1440-835						
		11	5-1444-835						
		12	5-1448-835						

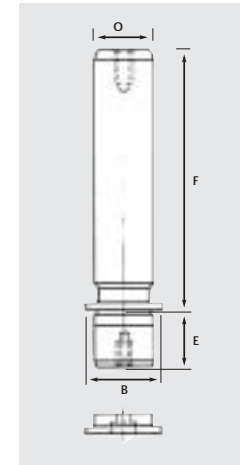

SinterLube® Bushings for Dies - INCH (-335, -345, -385)

- Ideal for retro-fits to improve productivity and decrease costly maintenance.
- Proven quality and dependability in dies for years.
- Readily available.
- Oversize press fit end for die shoe and nominal size end for bushing.
- Interchangeable with familiar brands.

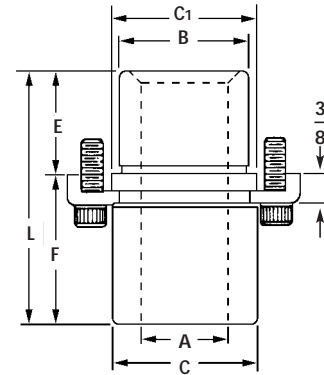

Short Shoulder Bushings



Inside Diameter A		E	C	C1	F	L	SinterLube® Catalog Number
Nom.	Dec.						
1"	1.000	1 1/2	1.72	1.84	15/16	13/16	6-08-335
1 1/4"	1.250	1 3/4	1.95	2.09	1 1/8	13/16	6-10-335
1 1/2"	1.500	2	2.19	2.35	1 3/16	2	6-12-335
1 3/4"	1.750	2 1/4	2.50	2.66	1 3/8	1	6-14-335
2"	2.000	2 1/2	2.91	2.95	1 5/8	1	6-16-335
2 1/2"	2.500	3 1/4	3.66	3.66	1 7/8	1	6-20-335
3"	3.000	3 3/4	4.19	4.28	1 7/8	1	6-24-335

Standard Shoulder Bushings



Inside Diameter A		E	C	C1	F	L	SinterLube® Catalog Number
Nom.	Dec.						
1"	1.000	1 1/2	1.72	1.84	15/16	1 3/4	6-08-345
1 1/4"	1.250	1 3/4	1.95	2.09	1 1/8	2	6-10-345
1 1/2"	1.500	2	2.19	2.35	1 3/16	2	6-12-345
1 3/4"	1.750	2 1/4	2.50	2.66	1 3/8	2	6-14-345
2"	2.000	2 1/2	2.91	2.95	1 5/8	2	6-16-345
2 1/2"	2.500	3 1/4	3.66	3.66	1 7/8	2 1/2	6-20-345
3"	3.000	3 3/4	4.19	4.28	1 7/8	2 1/2	6-24-345

Extra Long Shoulder Bushings



Inside Diameter A		E	C	C1	F	L	SinterLube® Catalog Number
Nom.	Dec.						
1"	1.000	1 1/2	1.72	1.84	15/16	3	6-08-385
1 1/4"	1.250	1 3/4	1.95	2.09	1 1/8	3	6-10-385
1 1/2"	1.500	2	2.19	2.35	1 3/16	3	6-12-385
1 3/4"	1.750	2 1/4	2.50	2.66	1 3/8	3	6-14-385
2"	2.000	2 1/2	2.91	2.95	1 5/8	3	6-16-385
2 1/2"	2.500	3 1/4	3.66	3.66	1 7/8	3	6-20-385
3"	3.000	3 3/4	4.19	4.28	1 7/8	3	6-24-385

For clamp data, guide pin tap sizes and seating torques, please refer to the Ready Die Set and Guiding Catalog.

Precision Pin Selection Guide

Nominal Pin Diameter O	Length L	Catalog Number
18	100	5-1810-82
	110	5-1811-82
	120	5-1812-82
	130	5-1813-82
	140	5-1814-82
	150	5-1815-82
	160	5-1816-82
	170	5-1817-82
	180	5-1818-82
	190	5-1819-82
200	5-1820-82	
19	100	5-1910-82
	110	5-1911-82
	120	5-1912-82
	130	5-1913-82
	140	5-1914-82
	150	5-1915-82
	160	5-1916-82
	170	5-1917-82
	180	5-1918-82
	190	5-1919-82
200	5-1920-82	
24	100	5-2410-82
	110	5-2411-82
	120	5-2412-82
	130	5-2413-82
	140	5-2414-82
	150	5-2415-82
	160	5-2416-82
	170	5-2417-82
	180	5-2418-82
	190	5-2419-82
200	5-2420-82	
220	5-2422-82	
240	5-2424-82	
260	5-2426-82	
280	5-2428-82	
25	100	5-2510-82
	110	5-2511-82
	120	5-2512-82
	130	5-2513-82
	140	5-2514-82
	150	5-2515-82
	160	5-2516-82
	170	5-2517-82
	180	5-2518-82
	190	5-2519-82
200	5-2520-82	
220	5-2522-82	
240	5-2524-82	
260	5-2526-82	
280	5-2528-82	
30	130	5-3013-82
	140	5-3014-82
	150	5-3015-82
	160	5-3016-82
	170	5-3017-82
	180	5-3018-82
	190	5-3019-82
	200	5-3020-82
	220	5-3022-82
	240	5-3024-82
260	5-3026-82	
280	5-3028-82	
320	5-3020-82	
32	130	5-3213-82
	140	5-3214-82
	150	5-3215-82
	160	5-3216-82
	170	5-3217-82
	180	5-3218-82
	190	5-3219-82
	200	5-3220-82
	220	5-3222-82
	240	5-3224-82
260	5-3226-82	
280	5-3228-82	
320	5-3232-82	

Nominal Pin Diameter O	Length L	Catalog Number
40	130	5-4013-82
	140	5-4014-82
	150	5-4015-82
	160	5-4016-82
	170	5-4017-82
	180	5-4018-82
	190	5-4019-82
	200	5-4020-82
	220	5-4022-82
	240	5-4024-82
260	5-4026-82	
280	5-4028-82	
320	5-4032-82	
360	5-4036-82	
42	130	5-4213-82
	140	5-4214-82
	150	5-4215-82
	160	5-4216-82
	170	5-4217-82
	180	5-4218-82
	190	5-4219-82
	200	5-4220-82
	220	5-4222-82
	240	5-4224-82
260	5-4226-82	
280	5-4228-82	
320	5-4232-82	
360	5-4236-82	
50	160	5-5016-82
	180	5-5018-82
	200	5-5020-82
	220	5-5022-82
	240	5-5024-82
	260	5-5026-82
	280	5-5028-82
	320	5-5032-82
	330	5-5033-82
	360	5-5036-82
400	5-5040-82	
450	5-5045-82	
52	160	5-5216-82
	180	5-5218-82
	200	5-5220-82
	220	5-5222-82
	240	5-5224-82
	260	5-5226-82
	280	5-5228-82
	320	5-5232-82
	330	5-5233-82
	360	5-5236-82
400	5-5240-82	
450	5-5245-82	
63	200	5-6320-82
	220	5-6322-82
	240	5-6324-82
	260	5-6326-82
	280	5-6328-82
	320	5-6332-82
	360	5-6336-82
	400	5-6340-82
	450	5-6345-82
	500	5-6350-82
80	240	5-8024-82
	260	5-8026-82
	280	5-8028-82
	320	5-8032-82
	360	5-8036-82
	400	5-8040-82
	450	5-8045-82
500	5-8050-82	

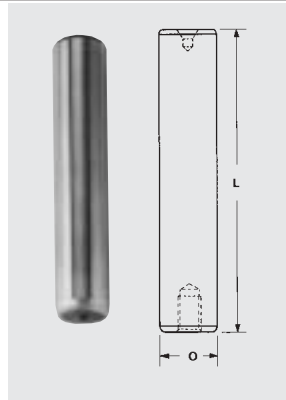

Demountable Pin Selection Guide

D1	D3	E	Length F	Catalog Number
18	25.6	20	70	5-1807-83
			80	5-1808-83
			90	5-1809-83
			100	5-1810-83
			110	5-1811-83
			120	5-1812-83
			130	5-1813-83
			140	5-1814-83
			150	5-1815-83
			160	5-1816-83
19	25.6	20	70	5-1907-83
			80	5-1908-83
			90	5-1909-83
			100	5-1910-83
			110	5-1911-83
			120	5-1912-83
			130	5-1913-83
			140	5-1914-83
			150	5-1915-83
			160	5-1916-83
24	32.6	24	70	5-2407-83
			80	5-2408-83
			90	5-2409-83
			100	5-2410-83
			110	5-2411-83
			120	5-2412-83
			130	5-2413-83
			140	5-2414-83
			150	5-2415-83
			160	5-2416-83
170	5-2417-83			
180	5-2418-83			
200	5-2420-83			
25	32.6	24	70	5-2507-83
			80	5-2508-83
			90	5-2509-83
			100	5-2510-83
			110	5-2511-83
			120	5-2512-83
			130	5-2513-83
			140	5-2514-83
			150	5-2515-83
			160	5-2516-83
170	5-2517-83			
180	5-2518-83			
200	5-2520-83			
30	40.6	30	90	5-3009-83
			100	5-3010-83
			110	5-3011-83
			120	5-3012-83
			130	5-3013-83
			140	5-3014-83
			150	5-3015-83
			160	5-3016-83
			170	5-3017-83
			180	5-3018-83
200	5-3020-83			
32	40.6	30	90	5-3209-83
			100	5-3210-83
			110	5-3211-83
			120	5-3212-83
			130	5-3213-83
			140	5-3214-83
			150	5-3215-83
			160	5-3216-83
			170	5-3217-83
			180	5-3218-83
200	5-3220-83			
220	5-3222-83			
240	5-3224-83			
280	5-3228-83			

Demountable Pin
 Selection Guide Continued

D1	D3	E	Length F	Catalog Number
40	50.8	37	100	5-4010-83
			110	5-4011-83
			120	5-4012-83
			130	5-4013-83
			140	5-4014-83
			150	5-4015-83
			160	5-4016-83
			170	5-4017-83
			180	5-4018-83
			200	5-4020-83
42	50.8	37	220	5-4022-83
			240	5-4024-83
			280	5-4028-83
			100	5-4210-83
			110	5-4211-83
			120	5-4212-83
			130	5-4213-83
			140	5-4214-83
			150	5-4215-83
			160	5-4216-83
50	63.8	45	170	5-4217-83
			180	5-4218-83
			200	5-4220-83
			220	5-4222-83
			240	5-4224-83
			280	5-4228-83
			110	5-5011-83
			120	5-5012-83
			130	5-5013-83
			140	5-5014-83
52	63.8	45	150	5-5015-83
			160	5-5016-83
			170	5-5017-83
			180	5-5018-83
			200	5-5020-83
			220	5-5022-83
			240	5-5024-83
			260	5-5026-83
			280	5-5028-83
			320	5-5032-83
63	76	49	360	5-5036-83
			400	5-5040-83
			110	5-5211-83
			120	5-5212-83
			130	5-5213-83
			140	5-5214-83
			150	5-5215-83
			160	5-5216-83
			170	5-5217-83
			180	5-5218-83
80	93	60	200	5-5220-83
			220	5-5222-83
			240	5-5224-83
			260	5-5226-83
			280	5-5228-83
			320	5-5232-83
			360	5-5236-83
			400	5-5240-83
			120	5-6312-83
			140	5-6314-83
80	93	60	160	5-6316-83
			180	5-6318-83
			200	5-6320-83
			220	5-6322-83
			240	5-6324-83
			280	5-6328-83
			320	5-6332-83
			360	5-6336-83
			400	5-6340-83
			180	5-8018-83
200	5-8020-83			
220	5-8022-83			
240	5-8024-83			
280	5-8028-83			
320	5-8032-83			
360	5-8036-83			
400	5-8040-83			

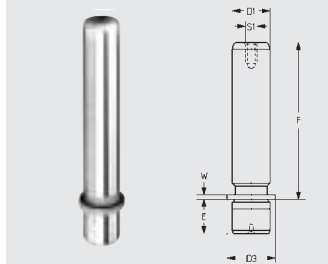

SinterLube® Bushings
 for Dies - METRIC

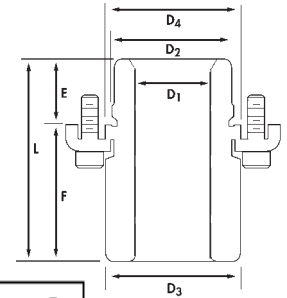

Low Profile Bushings

D ₁ mm	D ₂ mm	D ₃ mm	D ₄ mm	E mm	F mm	L mm	X mm	SinterLube® Catalog Number
19	28	28	32.5	18	10	28	6	6-1928-38
25	38	36	47	23	10	33	6	6-2538-38
32	45	43	54	30	10	40	10	6-3245-38
40	54	48	63	38	14	52	10	6-4054-38
50	65	64	75	48	14	62	20	6-5065-38
63	81	79	93	61	14	75	20	6-6381-38
80	100	99	115	78	14	92	32	6-8010-38



Short Shoulder Bushings

D ₁ mm	D ₂ mm	D ₃ mm	D ₄ mm	E mm	F mm	L mm	SinterLube® Catalog Number
19	28	28.5	32.5	18	16	34	6-1928-33
25	38	44	47	23	21	44	6-2538-33
32	45	51	54	25	21	48	6-3245-33
40	54	60	63	30	21	51	6-4054-33
50	65	73	75	35	25	60	6-5065-33
63	81	90	93	48	27	75	6-6381-33
80	100	110	115	48	27	75	6-8010-33



Standard Shoulder Bushings

D ₁ mm	D ₂ mm	D ₃ mm	D ₄ mm	E mm	F mm	L mm	SinterLube® Catalog Number
19	28	28.5	32.5	18	32	50	6-1928-34
25	38	44	47	23	47	70	6-2538-34
32	45	51	54	25	50	75	6-3245-34
40	54	60	63	30	50	80	6-4054-34
50	65	73	75	35	50	85	6-5065-34
63	81	90	93	48	52	100	6-6381-34
80	100	110	115	48	52	100	6-8010-34



Extra Long Shoulder Bushings

D ₁ mm	D ₂ mm	D ₃ mm	D ₄ mm	E mm	F mm	L mm	SinterLube® Catalog Number
25	38	44	47	23	75	98	6-2538-35
32	45	51	54	25	75	100	6-3245-35
40	54	60	63	30	85	115	6-4054-35
50	65	73	75	35	100	135	6-5065-35
63	81	90	93	48	100	148	6-6381-35



Guide Pins, NAAMS Standard

D	L	A	B	R	Catalog Number	NAAMS Code
32	140	45	8	2	5-NP32-140	G513214
	160				5-NP32-160	G513216
	180				5-NP32-180	G513218
	200				5-NP32-200	G513220
40	160	56	8	2	5-NP40-160	G514016
	180				5-NP40-180	G514018
	200				5-NP40-200	G514020
	225				5-NP40-225	G514022
	250				5-NP40-250	G514025
50	160	70	10	2.5	5-NP50-160	G515016
	180				5-NP50-180	G515018
	200				5-NP50-200	G515020
	225				5-NP50-225	G515022
	250				5-NP50-250	G515025
	280				5-NP50-280	G515028
	315				5-NP50-315	G515031
63	200	80	10	2.5	5-NP63-200	G516320
	225				5-NP63-225	G516322
	250				5-NP63-250	G516325
	280				5-NP63-280	G516328
	315				5-NP63-315	G516331
	355				5-NP63-355	G516335
	400				5-NP63-400	G516340
	500				5-NP63-500	G516350
80	250	100	10	3	5-NP80-250	G518025
	280				5-NP80-280	G518028
	315				5-NP80-315	G518031
	355				5-NP80-355	G518035
	400				5-NP80-400	G518040
	500				5-NP80-500	G518050
100	315	125	10	3	5-NP100-315	G511031
	355				5-NP100-355	G511035
	400				5-NP100-400	G511040
	500				5-NP100-500	G511050

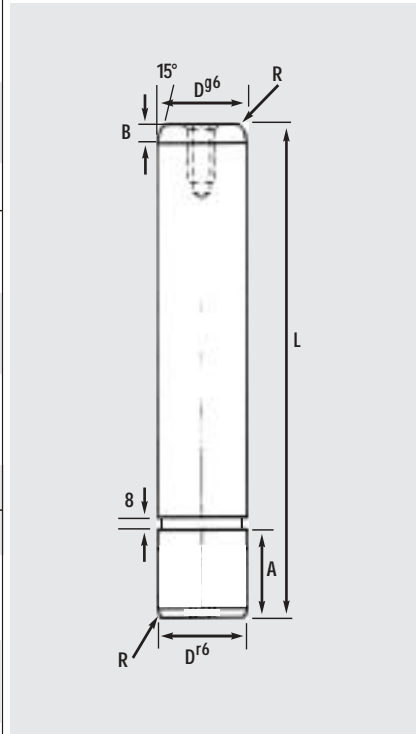

Material: AISI or SAE 1080/1020, case hardened to Rc 57-62, minimum depth of 0.8 mm.

SinterLube[®] Bushings, NAAMS Standard

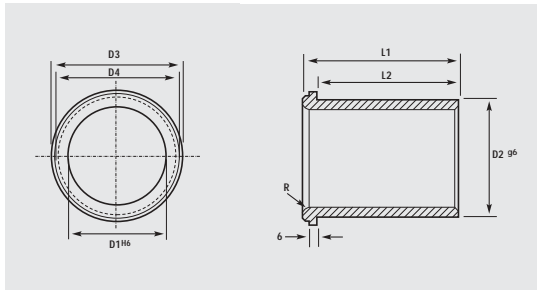

NAAMS SinterLube bushings are supplied with (3) (NAAMS #G720000) toe clamps, unless otherwise specified.

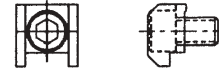

Clamp #6-99-1 NAAMS #G720000

D ₁ mm	D ₂ mm	D ₃ mm	D ₄ mm	L ₁ mm	L ₂ mm	R mm	Catalog Number	NAAMS Code
32	40	50	40	50	40	3	6-NM32-50	G613250
40	50	63	50	63	50	3	6-NM40-63	G614063
50	63	71	63	71	56	5	6-NM50-71	G615071
63	80	90	80	80	63	6	6-NM63-80	G616380
80	100	112	100	100	80	8	6-NM80-100	G618010
100	125	140	125	125	106	10	6-NM100-125	G611012

SinterLube[®] Pad Bushings, NAAMS Standard

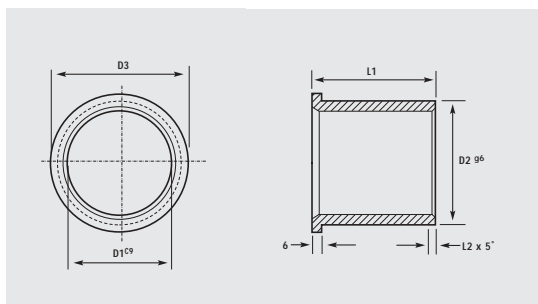

Material: Self-lubricating SinterLube[®] alloy bushings supplied with (3) toe clamps.

D ₁ mm	D ₂ mm	D ₃ mm	L ₁ mm	L ₂ mm	Catalog Number	NAAMS Code
32	40	50	50	4	6-NM32P-50	G713250
40	50	63	55	5	6-NM40P-55	G714055
50	63	71	63	6	6-NM50P-63	G715063
63	80	90	75	8	6-NM63P-75	G716375
80	100	112	90	10	6-NM80P-90	G718090
100	125	140	115	12	6-NM100P-115	G711011

Guide Pins, *DIN Standard 9833*

D1 g6	D2 r6	L1	L2	Catalog Number
25	25	125	40	5-2512-850
		140		5-2514-850
		160		5-2516-850
32	32	140	45	5-3214-850
		160		5-3216-850
		180		5-3218-850
		200		5-3220-850
40	40	160	56	5-4016-850
		180		5-4018-850
		200		5-4020-850
		224		5-4022-850
		250		5-4025-850
50	50	280	70	5-4028-850
		160		5-5016-850
		180		5-5018-850
		200		5-5020-850
		224		5-5022-850
		250		5-5025-850
63	63	280	80	5-5028-850
		315		5-5031-850
		355		5-5035-850
		200		5-6320-850
		224		5-6322-850
		250		5-6325-850
80	80	280	100	5-6328-850
		315		5-6331-850
		355		5-6335-850
		250		5-8025-850
		280		5-8028-850
100	100	315	125	5-8031-850
		355		5-8035-850
		400		5-8040-850
		355		5-1035-850
		400		5-1040-850

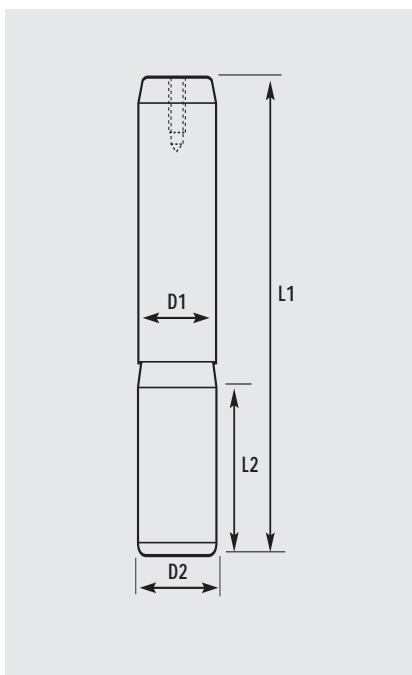

SinterLube® Bushings, DIN Standard 9834

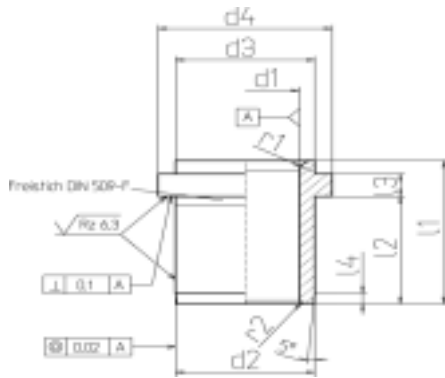

D ₁ mm H7	D ₂ mm h6	D ₃ mm -0.25	D ₄ mm -0.8	L ₁ mm -1 -1.6	L ₂ mm -2 -2.5	L ₃ mm ±0.1	L ₄ mm ± 1	R ₁ mm	R ₂ mm	Clamp	Catalog Number
25	32	32	40	40	32	6.3	3	3	1	6-78-1	6-2532-78
32	40	40	50	50	40	6.3	4	3	1	6-78-1	6-3240-78
40	50	50	63	63	50	6.3	5	3	1	6-78-1	6-4050-78
50	63	63	71	71	56	6.3	6.3	5	1	6-78-1	6-5063-78
63	80	80	90	80	63	10	8	6	1	6-78-2	6-6380-78
80	100	100	112	100	80	10	10	8	1	6-78-2	6-8010-78
100	125	125	140	125	106	10	12.5	10	1	6-78-2	6-1012-78

Catalog Number	t ₂ -0.3	b ₁	b ₂	d ₂ +0.2	d ₃ +0.2	h	l -0.3	t ₁ +0.2	t ₃ +0.3	Screw (included)
6-78-1	6.3	20	7.5	7	11	10	20	7	5	M6 x 16
6-78-2	10	32	11	11.5	17.5	16	32	11.5	10	M10 x 20

Mounting Dimensions

D ₁	D ₄ ±0.3	No. of Clamps per Bushing
25	58	1
32	66	1
40	79	1
50	89	1
63	123	2
80	143	2
100	168	2

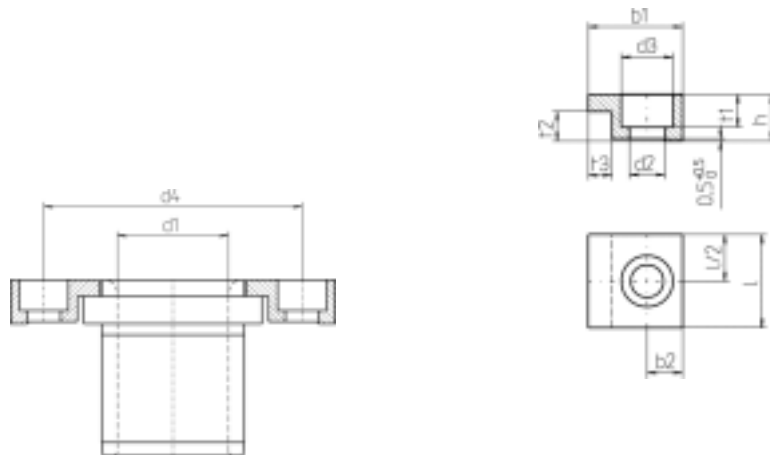

Guide Pins, AFNOR Standard

Bottom retained guide pins, AFNOR E60 050

A Ø	L	B	C	e	Catalog Number
32	160	10	12	8	5-3216-844
	200				5-3220-844
	220				5-3222-844
40	180	12	12	8	5-4018-844
	200				5-4020-844
	220				5-4022-844
	280				5-4028-844
50	220	16	12	8	5-5022-844
	280				5-5028-844
	400				5-5040-844
63	280	16	18	13	5-6328-844

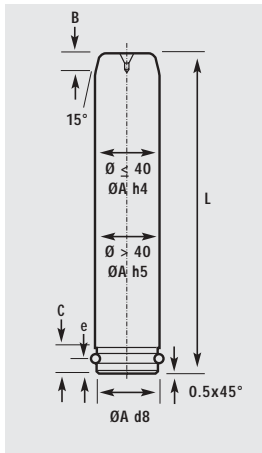

Center retained guide pins, AFNOR E63 061

A Ø	L	B	C	D	Catalog Number
32	140	10	32	12	5-3214-840
	160				5-3216-840
	200				5-3220-840
40	180	12	63	12	5-4018-840
	200				5-4020-840
	220				5-4022-840
50	220	16	80	12	5-5022-840
	280				5-5028-840
63	250	16	100	18	5-6325-840
	280				5-6328-840
	315				5-6332-840
80	315	16	125	18	5-8032-840
	355				5-8036-840

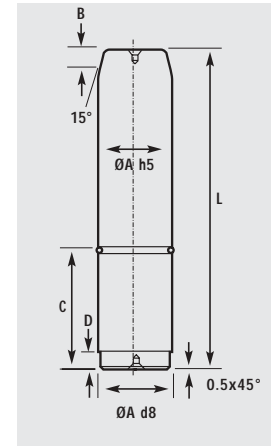

Rings for Retained Guide Pins

Ø	D	d	Catalog Number
32	28	4	6-0032-844
40	36	4	6-0040-844
50	46	4	6-0050-844
63	57	6	6-0063-844
80	74	6	6-0080-844

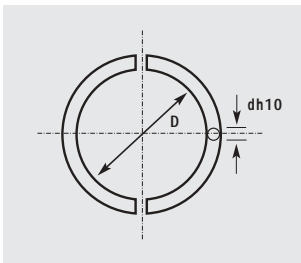

Clamps for Center Retained Guide Pins

Ø A	D	E	F	Ø G	Catalog Number
32	10	56	36	6.6	6-0032-840
40	12	70	50	6.6	6-0040-840
50	14	80	55	9	6-0050-840
63	18	100	70	11	6-0063-840
80	20	110	80	14	6-0080-840

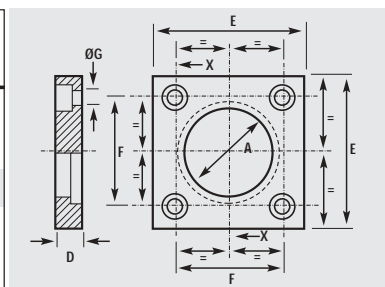

SinterLube® Bushings, AFNOR Standard

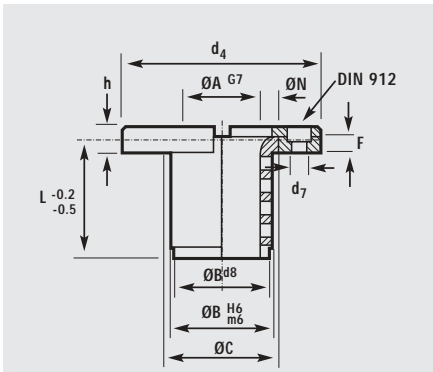

Ø A	L	Ø B	Ø C	F	Catalog Number
32	50	44	50	6	6-3244-79
40	63	52	60	8	6-4052-79
50	80	63	71	10	6-5063-79
63	100	80	90	12	6-6380-79
80	125	100	112	16	6-8010-79

Bushing Hardware

Ø	Ø M	Ø N	Ø d ⁴	h	Ø d ⁷	e ³	e ²	e ¹	Catalog Number
32	40	51	80	12	6.6		21	25	6-0032-790
40	50	61	100	12	6.6	41	14	38.5	6-0040-790
50	63	72	125	16	9	49	17	46	6-0050-790
63	80	91	140	20	11	57.5	17	55	6-0063-790
80	100	113	180	25	14	72	20	70	6-0080-790

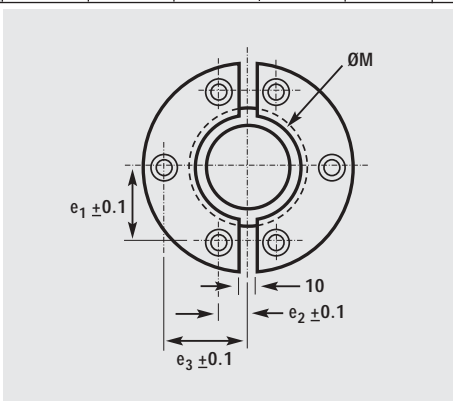

Mold Guide Pins, INCH

Nominal Pin Ø	L1 overall length	L3	Catalog Number
3/4"	1 3/4	7/8	6-16-MP
	2 1/4	7/8	6-22-MP
	2 3/4	7/8	6-26-MP
	3 1/4	7/8	6-32-MP
	3 3/4	7/8	6-36-MP
	4 1/4	1 3/8	6-42-MP
	4 3/4	1 3/8	6-46-MP
	5 1/4	1 3/8	6-52-MP
	5 3/4	1 7/8	6-56-MP
	6 1/4	1 7/8	6-62-MP
	6 3/4	1 7/8	6-66-MP
	7 1/4	1 7/8	6-72-MP
	7 3/4	1 7/8	6-76-MP
	7/8"	1 3/4	7/8
2 1/4		7/8	7-22-MP
2 3/4		7/8	7-26-MP
3 1/4		7/8	7-32-MP
3 3/4		7/8	7-36-MP
4 1/4		1 3/8	7-42-MP
4 3/4		1 3/8	7-46-MP
5 1/4		1 3/8	7-52-MP
5 3/4		1 3/8	7-56-MP
6 1/4		1 7/8	7-62-MP
6 3/4		1 7/8	7-66-MP
7 1/4		1 7/8	7-72-MP
7 3/4		1 7/8	7-76-MP
8 1/4		1 7/8	7-82-MP
8 3/4	1 7/8	7-86-MP	
9 1/4	1 7/8	7-92-MP	
1"	1 3/4	7/8	8-16-MP
	2 1/4	7/8	8-22-MP
	2 3/4	7/8	8-26-MP
	3 1/4	7/8	8-32-MP
	3 3/4	7/8	8-36-MP
	4 1/4	1 3/8	8-42-MP
	4 3/4	1 3/8	8-46-MP
	5 1/4	1 3/8	8-52-MP
	5 3/4	1 3/8	8-56-MP
	6 1/4	1 3/8	8-62-MP
	6 3/4	1 7/8	8-66-MP
	7 1/4	1 7/8	8-72-MP
	7 3/4	1 7/8	8-76-MP
	8 1/4	1 7/8	8-82-MP
8 3/4	1 7/8	8-86-MP	
9 1/4	1 7/8	8-92-MP	
9 3/4	1 7/8	8-96-MP	
10 1/4	1 7/8	8-102-MP	
10 3/4	1 7/8	8-106-MP	
11 1/4	1 7/8	8-112-MP	
11 3/4	1 7/8	8-116-MP	
12 1/4	1 7/8	8-122-MP	

3/4" - 1 1/2" dia. have taper length of 1/4".
 2" - 2 1/2" have taper length of 3/8".
 3" pins have XX radius.

Nominal Pin Ø	L1 overall length	L3	Catalog Number
1 1/4"	2 3/4	7/8	10-26-MP
	3 1/4	7/8	10-32-MP
	3 3/4	7/8	10-36-MP
	4 1/4	7/8	10-42-MP
	4 3/4	1 3/8	10-46-MP
	5 1/4	1 3/8	10-52-MP
	5 3/4	1 3/8	10-56-MP
	6 1/4	1 3/8	10-62-MP
	6 3/4	1 7/8	10-66-MP
	7 1/4	1 7/8	10-72-MP
	7 3/4	1 7/8	10-76-MP
	8 1/4	1 7/8	10-82-MP
	8 3/4	1 7/8	10-86-MP
	9 1/4	1 7/8	10-92-MP
	9 3/4	1 7/8	10-96-MP
10 1/4	1 7/8	10-102-MP	
10 3/4	1 7/8	10-106-MP	
11 1/4	1 7/8	10-112-MP	
11 3/4	1 7/8	10-116-MP	
12 1/4	1 7/8	10-122-MP	
12 3/4	1 7/8	10-126-MP	
13 3/4	1 7/8	10-136-MP	
14 3/4	1 7/8	10-146-MP	
15 3/4	1 7/8	10-156-MP	
1 1/2"	3 3/4	1 3/8	12-36-MP
	4 1/4	1 3/8	12-42-MP
	4 3/4	1 3/8	12-46-MP
	5 1/4	1 3/8	12-52-MP
	5 3/4	1 3/8	12-56-MP
	6 1/4	1 3/8	12-62-MP
	6 3/4	1 3/8	12-66-MP
	7 3/4	1 7/8	12-76-MP
	8 3/4	1 7/8	12-86-MP
	9 3/4	1 7/8	12-96-MP
	10 3/4	1 7/8	12-106-MP
	11 3/4	1 7/8	12-116-MP
	12 3/4	1 7/8	12-126-MP
	13 3/4	1 7/8	12-136-MP
	14 3/4	1 7/8	12-146-MP
15 3/4	1 7/8	12-156-MP	
2"	5 3/4	1 7/8	16-56-MP
	6 3/4	1 7/8	16-66-MP
	7 3/4	1 7/8	16-76-MP
	8 3/4	1 7/8	16-86-MP
	9 3/4	1 7/8	16-96-MP
	10 3/4	1 7/8	16-106-MP
	11 3/4	1 7/8	16-116-MP
	12 3/4	1 7/8	16-126-MP
	13 3/4	1 7/8	16-136-MP
	14 3/4	1 7/8	16-146-MP
	15 3/4	1 7/8	16-156-MP
	16 3/4	1 7/8	16-166-MP
	18 3/4	1 7/8	16-186-MP

Nominal Pin Ø	L1 overall length	L3	Catalog Number
2 1/2"	5 3/4	2 3/8	20-56-MP
	6 3/4	2 3/8	20-66-MP
	7 3/4	2 3/8	20-76-MP
	8 3/4	2 3/8	20-86-MP
	9 3/4	2 3/8	20-96-MP
	10 3/4	2 3/8	20-106-MP
	11 3/4	2 3/8	20-116-MP
	12 3/4	2 3/8	20-126-MP
	13 3/4	2 3/8	20-136-MP
	14 3/4	2 3/8	20-146-MP
3"	15 3/4	2 3/8	20-156-MP
	16 3/4	2 3/8	20-166-MP
	18 3/4	2 3/8	20-186-MP
	8 3/4	2 7/8	24-86-MP
	10 3/4	2 7/8	24-106-MP
	12 3/4	2 7/8	24-126-MP
	14 3/4	2 7/8	24-146-MP
	16 3/4	2 7/8	24-166-MP
	18 3/4	2 7/8	22-186-MP

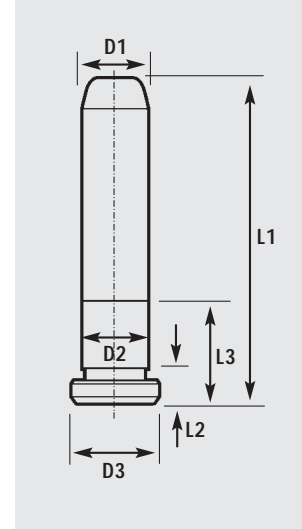

General Dimensions

Nom. I.D.	D1	D2	D3	L2
	+0.005 -0.000	+0.005 -0.000	+0.00 -0.005	+0.000 -0.005
3/4	0.749	0.7510	0.990	0.1870
7/8	0.874	0.8760	1.115	0.2500
1	0.999	1.0010	1.240	0.2500
1 1/4	1.249	1.2510	1.490	0.3120
1 1/2	1.499	1.5010	1.740	0.3120
2	1.999	2.0010	2.240	0.3120
2 1/2	2.499	2.5010	2.740	0.3120
3	2.999	3.0010	3.365	0.5000

Mold Guide Pins and SinterLube® Mold Bushings, METRIC

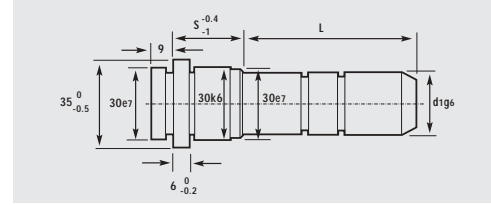
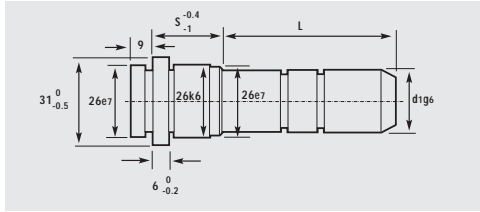

S	L	d ₁ = 18	
		Catalog Number	Catalog Number
22	35	017-1822035	017-2022035
	45	017-1822045	017-2022045
	65	017-1822065	017-2022065
	85	017-1822085	017-2022085
	115	017-1822115	017-2022115
27	35	017-1827035	017-2027035
	45	017-1827045	017-2027045
	65	017-1827065	017-2027065
	85	017-1827085	017-2027085
	105	017-1827105	017-2027105
	125	017-1827125	017-2027125
	165	017-1827165	017-2027165
36	35	017-1836035	017-2036035
	55	017-1836055	017-2036055
	75	017-1836075	017-2036075
	95	017-1836095	017-2036095
	115	017-1836115	017-2036115
	135	017-1836135	017-2036135
	165	017-1836165	017-2036165
46	45	017-1846045	017-2046045
	65	017-1846065	017-2046065
	85	017-1846085	017-2046085
	105	017-1846105	017-2046105
	135	017-1846135	017-2046135
	165	017-1846165	017-2046165
56	35	017-1856045	017-2056045
	55	017-1856055	017-2056055
	75	017-1856075	017-2056075
	95	017-1856095	017-2056095
	155	017-1856155	017-2056155
66	35	017-1866045	017-2066045
	55	017-1866055	017-2066055
	75	017-1866075	017-2066075
	95	017-1866095	017-2066095
	145	017-1866145	017-2066145
76	55	017-1876055	017-2076055
	75	017-1876075	017-2076075
	95	017-1876095	017-2076095
	135	017-1876135	017-2076135
96	55	017-1896055	017-2096055
	95	017-1896095	017-2096095

S	L	d ₁ = 22		d ₁ = 24	
		Catalog Number	Catalog Number	Catalog Number	Catalog Number
27	35	017-2227035	017-2427035		
	45	017-2227045	017-2427045		
	65	017-2227065	017-2427065		
	85	017-2227085	017-2427085		
	105	017-2227105	017-2427105		
	125	017-2227125	017-2427125		
	165	017-2227165	017-2427165		
36	35	017-2236035	017-2436035		
	55	017-2236055	017-2436055		
	75	017-2236075	017-2436075		
	95	017-2236095	017-2436095		
	115	017-2236115	017-2436115		
	135	017-2236135	017-2436135		
	165	017-2236165	017-2436165		
46	45	017-2246045	017-2446045		
	65	017-2246065	017-2446065		
	85	017-2246085	017-2446085		
	105	017-2246105	017-2446105		
	125	017-2246125	017-2446125		
	165	017-2246165	017-2446165		
	205	017-2246205	017-2446205		
56	55	017-2256055	017-2456055		
	75	017-2256075	017-2456075		
	95	017-2256095	017-2456095		
	115	017-2256115	017-2456115		
	165	017-2256165	017-2456165		
	205	017-2256205	017-2456205		
66	35	017-2266035	017-2466035		
	55	017-2266055	017-2466055		
	75	017-2266075	017-2466075		
	95	017-2266095	017-2466095		
	155	017-2266155	017-2466155		
76	55	017-2276055	017-2476055		
	75	017-2276075	017-2476075		
	95	017-2276095	017-2476095		
	115	017-2276115	017-2476115		
	145	017-2276145	017-2476145		
96	55	017-2296055	017-2496055		
	75	017-2296075	017-2496075		
	95	017-2296095	017-2496095		
116	75	017-22116075	017-24116075		
	115	017-22116115	017-24116115		
	155	017-22116155	017-24116155		
136	95	017-22136095	017-24136095		
	135	017-22136135	017-24136135		
156	155	017-22156155	017-24156155		

Mold Guide Pins and SinterLube® Mold Bushings, METRIC

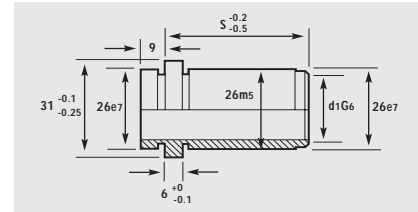
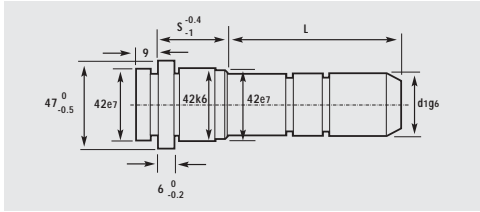

S	L	d ₁ = 30	
		Catalog Number	Catalog Number
27	45	017-3027045	017-3227045
	65	017-3027065	017-3227065
	105	017-3027105	017-3227105
	165	017-3027165	017-3227165
36	55	017-3036055	017-3236055
	75	017-3036075	017-3236075
	95	017-3036095	017-3236095
	115	017-3036115	017-3236115
	245	017-3036245	017-3236245
46	45	017-3046045	017-3246045
	65	017-3046065	017-3246065
	85	017-3046085	017-3246085
	105	017-3046105	017-3246105
	245	017-3046245	017-3246245
56	55	017-3056055	017-3256055
	75	017-3056075	017-3256075
	95	017-3056095	017-3256095
	115	017-3056115	017-3256115
	135	017-3056135	017-3256135
	245	017-3056245	017-3256245
66	75	017-3066075	017-3266075
	95	017-3066095	017-3266095
	115	017-3066115	017-3266115
	245	017-3066245	017-3266245
76	95	017-3076095	017-3276095
	115	017-3076115	017-3276115
	155	017-3076155	017-3276155
	225	017-3076225	017-3276225
96	95	017-3096095	017-3296095
	115	017-3096115	017-3296115
	155	017-3096155	017-3296155
116	115	017-30116115	017-32116115
	155	017-30116155	017-32116155
136	95	017-30136095	017-32136095
	115	017-30136115	017-32136115
	155	017-30136155	017-32136155
156	115	017-30156115	017-32156115
	155	017-30156155	017-32156155

S	d ₁ = 18	
	Catalog Number	Catalog Number
22	009-18022	009-20022
27	009-18027	009-20027
36	009-18036	009-20036
46	009-18046	009-20046
56	009-18056	009-20056
66	009-18066	009-20066
76	009-18076	009-20076
96	009-18096	009-20096

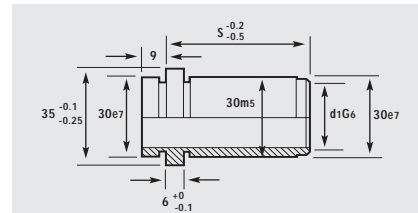

S	d ₁ = 22	
	Catalog Number	Catalog Number
22	009-22022	009-24022
27	009-22027	009-24027
36	009-22036	009-24036
46	009-22046	009-24046
56	009-22056	009-24056
66	009-22066	009-24066
76	009-22076	009-24076
96	009-22096	009-24096
116	009-22116	009-24116

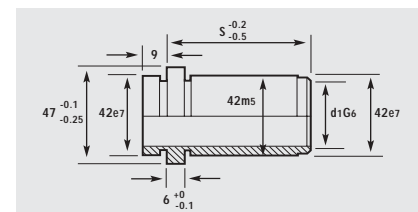

S	d ₁ = 30	
	Catalog Number	Catalog Number
27	009-30027	009-32027
36	009-30036	009-32036
46	009-30046	009-32046
56	009-30056	009-32056
66	009-30066	009-32066
76	009-30076	009-32076
96	009-30096	009-32096
116	009-30116	009-32116

SinterLube® Method of Use

For best results, we recommend that you apply an initial coat of lubricant to the inside diameter of each SinterLube bushing before starting production. Ideally, the lubricant should be a high viscosity oil of the type available from Ready and its distributors:

- 1 quart catalog no. 6-64-52
- 1 gallon catalog no. 6-128-52

Held in place by the many pores that make up the SinterLube bushing's sintered surface, the oil helps ease the operating severity as the guide pins and bushings seat themselves. Once initial wear-in is complete, the anti-friction particles embedded in the bronze matrix take over, and maintain proper operating conditions.

Take A Closer Look ...

Actual magnified views of bushing cross sections.

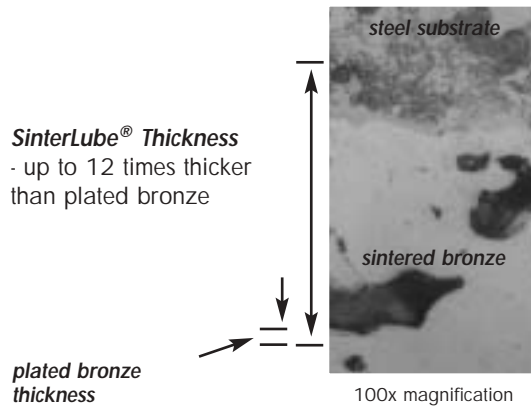

This view reveals the greater bronze thickness and the porosity of our SinterLube® Bushing.

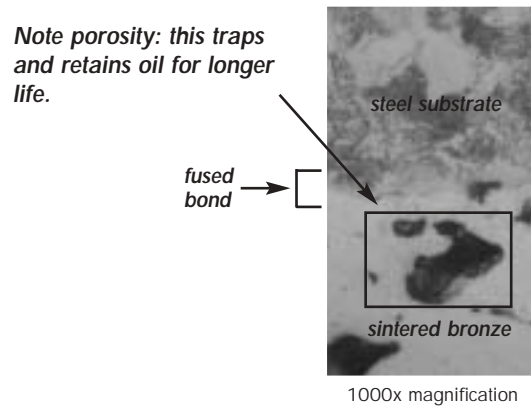

This view reveals the fusion bonding of the thick SinterLube® layer to the steel substrate.

Compare The Thickness ...

Nominal Diameter Ø	Plated Bronze Layer Thickness	READY SinterLube® Layer Thickness
1"	0.002"	0.021"
1 1/4"	0.002"	0.022"
1 1/2"	0.002"	0.023"
1 3/4"	0.002"	0.024"
2"	0.002"	0.025"
2 1/2"	0.002"	0.025"
3"	0.002"	0.025"



The innovator of our industry®

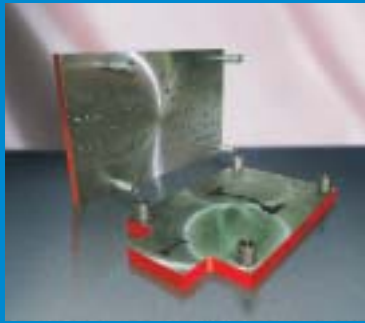

READY Die Sets & Machining



DESIGN₂-TITE® Gas Springs & Manifolds



SELECTIVE FIT® Guiding Elements



READY BENDERS® Forming Tools



CAMDRIVE® Mechanical Cams



HYDROCAM® Hydraulic Cams



SUPERSPRING® Die Springs



READYCad 3D Cad Design Software



The Innovator of Our Industry[®]

Our factories and offices:

U.S.A. • U.K. • France • Belgium • Germany • Sweden • Netherlands • Singapore

READY TECHNOLOGY, INC.

333 Progress Rd. • Dayton, OH 45449
 (800) 543-4355 • (937) 866-7200 • fax (937) 866-7226

630 Kiser St. • Dayton, OH 45404
 (800) 367-3437 • (937) 228-8181 • FAX: (937) 228-2928

BOLDEN DIE SUPPLY

189 Cobb Pkwy N C-5 • Marietta, GA 30065
 (800) 277-4278 • (770) 427-4278 • fax (770) 427-3282

www.readytechnology.com